

# CONFIGURING THE HDT240 FOR QUICK CONNECT APPLICATIONS

Revision 1.03 August 29, 2003

**INTRODUCTION** - The HDT240 was originally designed to function as a drop-in replacement for the many 2400bps modems that are no longer available due to Conexant's decision to discontinue production of the aging 224ATL modem chip. Therefore, the HDT240 comes factory configured to operate in the very simple mode of operation that was supported by the 224ATL chip. However, the HDT240 is based on one of Conexant's latest modem chips and is capable of operating in many sophisticated modes that could not be supported on older 224ATL based products. For instance, the HDT240 can be configured to provide:

- Speed buffering, error correction and flow control
- Data compression
- Fast connect answer sequences for transaction processing.

In this document, the fast connect option of the HDT240 will be discussed. You will be shown the two most common ways of using this option and will be presented with standard configurations that will allow you to rapidly deploy the HDT240 in this mode of operation.

**THE FAST CONNECT SEQUENCE** – Fast connect reduces the amount of time required for modems to connect. Through special sequences that must be executed in the answering modem, it is possible to reduce the connect time by well over fifty percent. Fast connect is only effective when operating at modulation speed of 2400bps, 1200bps or 300bps. However, these are the modulation speeds used for most transaction processing applications. In large transaction processing installations, the connect time reduction provided by the HDT240 can result in dramatic communications savings and can greatly reduce incoming trunk requirements.

**SPEED BUFFERING - THE MOST COMMON CONFIGURITON** – This mode of operation allows the host computer to communicate with the fast connect modem over the RS-232 interface at a fixed data rate. This data rate is usually 2400bps or greater. The fast connect modem is configured to automatically connect with incoming calls from either 2400, 1200 or 300bps modems. When a call is established, the fast connect modem uses internal buffering to match data rates between the host computer and calling modem. This mode of operation is simple, very reliable and highly recommended for new applications.

## SPEED BUFFERING

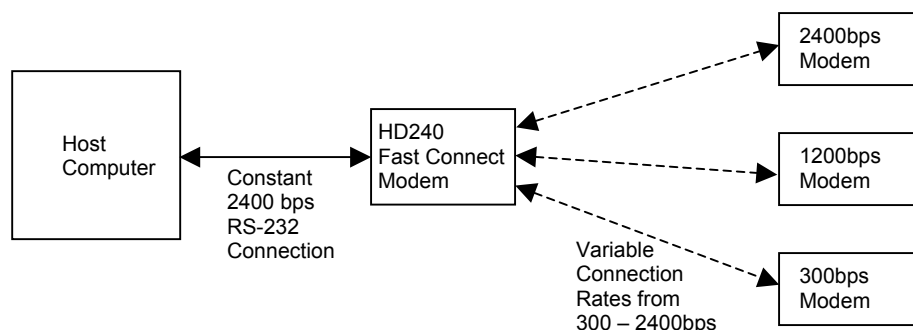

**DIRECT MODE – AN OLDER AND LESS COMMON CONFIGURITON** – In the past, modems had limited intelligence and no internal buffering. Therefore, they operated in Direct Mode where the host was required to vary the rate of the RS-232 connection to match that of the incoming call.

In the Direct Mode of operation, the host must initially establish an RS-232 connection with the HDT240 at 2400bps. When a remote modem calls in, the HDT240 will negotiate a connection with the calling modem and will then send a connect message to the host at 2400bps. This message will tell the host what connection rate was established with the calling modem. The HDT240 will then change the data rate of its RS-232 connection to match the rate of the calling modem. At this time, the host is also expected to adjust its RS-232 data rate to match that of the HDT240. When the call completes, the HDT240 will readjust its RS-232 rate to the 2400bps rate that had been in effect before the connection. The host is expected to make the same adjustment.

As you can see, this mode of operation is not as simple as speed buffered mode and presents many opportunities for timing/reliability issues. While we do not recommend that new applications be written to use Direct Mode, there are many existing applications that operate very efficiently in this mode of operation. It is for those applications that we provide and fully support this mode of operation.

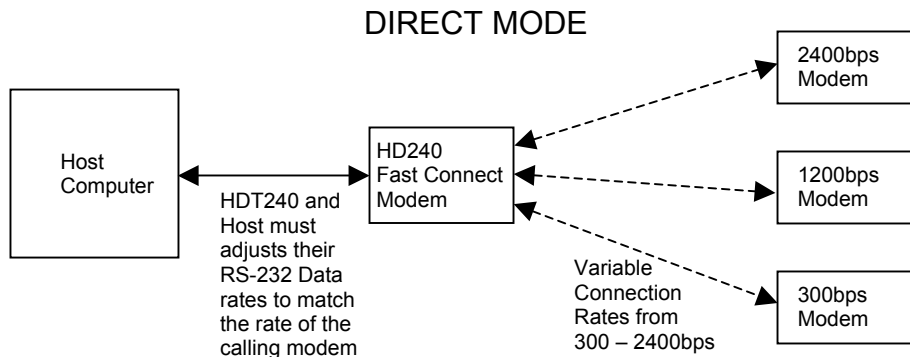

**CONFIGURING FOR SPEED BUFFERED MODE AND FAST CONNECT** – To configure the modem, you must attach a terminal or a PC with a terminal emulation program, such as Hyperterminal, to the RS-232 interface of the HDT240.

1. **SELECT THE PROPER BIT RATE AND CHARACTER FORMAT** – For instance, if your host computer will communicate with the HDT240 at 2400bps, 8 bit, no parity and one stop bit, make sure that the terminal or PC being used to configure the HDT240 is operating at that rate and that character format.
2. **MAKE SURE THAT YOU ARE COMMUNICATING WITH THE HDT240 AND NOT AN INTERNAL MODEM ON YOUR PC** – To do this type **ATI3** followed by the enter key. If you are communicating with the HDT240, it will respond as follows:

**HDT240 – Revision 1.03.**

3. START FROM A KNOWN CONFIGURATION – Type **AT&F&W** followed by the enter key. This will load factory defaults and initialize stored profile 0 with those defaults.
4. ENTER THE BASIC CONFIGURATION STRING – Type the following:  
**AT\$F1\N0&K0S0=1S7=8&W** followed by the enter key.
  - 4.1. **\$F1** - Enables Fast Connect.
  - 4.2. **N0** - Enables speed buffering.
  - 4.3. **&K0** - Disables flow control.
  - 4.4. **S0=1** - Enables auto-answer on the first ring.
  - 4.5. **S7=8** - Forces the HDT240 to hang up in 8 seconds if a connection has not been established.
  - 4.6. **&W** - Writes the configuration to stored profile 0. From this point, any time that the modem is powered on or reset, it will retrieve and configure itself from this profile.
5. OPTIONAL CONFIGURATION ISSUES – The command string shown above defines the basic characteristics for Speed Buffered Mode and Fast Connect. You may need to add parameters to control character echoing, response codes and response code formats. These commands all adhere to the standard **AT** format and can be found in the operations manual or quick start guide.
6. PAY ATTENTION TO DTR – The command string shown above leaves **&D2** configured in the HDT240. This means that the modem will rapidly hang up when DTR is dropped. Applications requiring maximum throughput should always use DTR as a method of hanging up and rapidly clearing the line for another incoming call. To do this, the application should drop DTR when it has completed a transaction and is ready to hang up. DTR should be left in the off state for at least 500 milliseconds and should then be returned to the on state so that the modem can rapidly take another incoming call.

**CONFIGURING FOR DIRECT MODE AND FAST CONNECT** – To configure the modem, you must attach a terminal or a PC with a terminal emulation program, such as Hyperterminal, to the RS-232 interface of the HDT240.

1. SELECT THE PROPER BIT RATE AND CHARACTER FORMAT – For instance, if your host computer will communicate with the HDT240 at 2400bps, 8 bit, no parity and one stop bit, make sure that the terminal or PC being used to configure the HDT240 is operating at that rate and that character format.
2. MAKE SURE THAT YOU ARE COMMUNICATING WITH THE HDT240 AND NOT AN INTERNAL MODEM ON YOUR PC – To do this type **ATI3** followed by the enter key. If you are communicating with the HDT240, it will respond as follows:  
**HDT240 – Revision 1.03.**
3. START FROM A KNOWN CONFIGURATION – Type **AT&F&W** followed by the enter key. This will load factory defaults and initialize stored profile 0 with those defaults.
4. ENTER THE BASIC CONFIGURATION STRING – Type the following:  
**AT\$F1N1S0=1S7=8&W** followed by the enter key.

- 4.1. **\$F1** - Enables Fast Connect.
  - 4.2. **\N1** - Enables direct mode.
  - 4.3. **S0=1** - Enables auto-answer on the first ring.
  - 4.4. **S7=8** - Forces the HDT240 to hang up in 8 seconds if a connection has not been established.
  - 4.5. **&W** - Writes the configuration to stored profile 0. From this point, any time that the modem is powered on or reset, it will retrieve and configure itself from this profile.
5. **OPTIONAL CONFIGURATION ISSUES** – The command string shown above defines the basic characteristics for Direct Mode and Fast Connect. You may need to add parameters to control character echoing, response codes and response code formats. These commands all adhere to the standard **AT** format and can be found in the operations manual or quick start guide.
  6. **PAY ATTENTION TO DTR** – The command string shown above leaves **&D2** configured in the HDT240. This means that the modem will rapidly hang up when DTR is dropped. Applications requiring maximum throughput should always use DTR as a method of hanging up and rapidly clearing the line for another incoming call. To do this, the application should drop DTR when it has completed a transaction and is ready to hang up. DTR should be left in the off state for at least 500 milliseconds and should then be returned to the on state so that the modem can rapidly take another incoming call.